

The Eaton logo, consisting of the word "EATON" in a bold, white, sans-serif font with a vertical line to its right, set against a dark blue background.The Cutler-Hammer logo, consisting of the words "Cutler-Hammer" in a white, serif font, set against a dark blue background.

**Medium Voltage Generator  
Vacuum Circuit Breakers**

Product Focus

A high-angle, wide shot of a large industrial facility, likely a power plant or refinery. The scene is dominated by a complex network of metal walkways, railings, and pipes. In the foreground, two workers wearing bright red safety jackets and white hard hats stand on a dark, gridded metal platform. The background shows more industrial structures, including large cylindrical tanks and intricate piping systems. The lighting is a mix of bright overhead lights and a deep blue ambient light, creating a dramatic and industrial atmosphere.

**Protect Yourself from Expensive  
Unplanned Outages while Improving  
Uptime, Reliability and Safety, with  
Eaton's Power Generation Protection.**

# Medium Voltage Protection for 25 to 105 Megawatt Generation.



Power generation is one mean application in today's green world.

Generator circuits have unique characteristics that require specially designed and tested circuit breakers. The IEEE approved a special industry standard to address these characteristics. Eaton Corporation has dedicated years of research, design, enhancement and testing to create Cutler-Hammer® VCP-WG Circuit Breakers that meet, and even exceed, the rigorous service duty requirements of generator circuit application defined by IEEE.

Count on Eaton's Cutler-Hammer innovative technology to handle high continuous AC current and voltage, then safely switch through extreme out-of-phase voltages and high-stress DC currents using "clean and green" vacuum interruption, without fail for over 10,000 normal operations — the Eaton VCP-WG, the World's Generator Breaker.

1



2



3

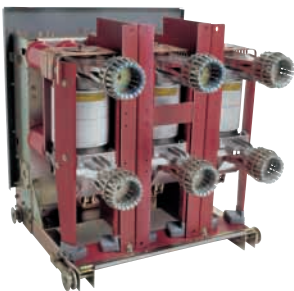

4

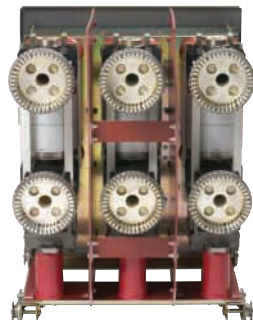

**1. Front View**

Up to 15 kV  
Up to 63 kA  
Up to 3000 A

**2. Front View**

Up to 15 kV  
Up to 75 kA  
Up to 4000 A

**3. Rear View**

Up to 15 kV  
Up to 63 kA  
Up to 3000 A

**4. Rear View**

Up to 15 kV  
Up to 75 kA  
Up to 4000 A

# Handle High Continuous Current, Quietly and Compactly.

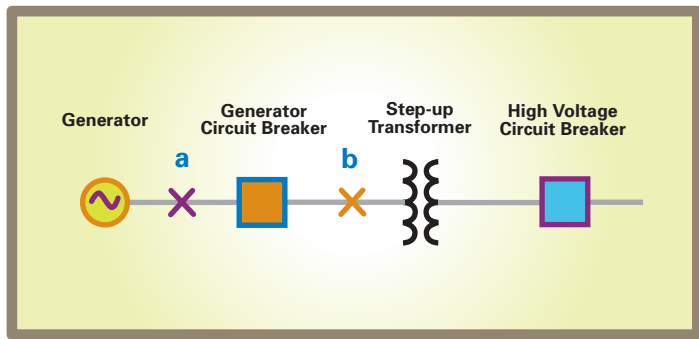

Cutler-Hammer VCP-WG Circuit Breakers go above and beyond the strict service duty requirements set forth by IEEE for generator circuit applications, including:

- Generator Circuit Configuration
- High Continuous Current Levels
- Unique Fault Current Conditions
  - Transformer-fed Faults
  - Generator-fed Faults
- Unique Voltage Conditions
  - Very Fast RRRV
  - Out-of-Phase Switching

## Generator Circuit Configuration

The transformer and generator can be in close proximity to the circuit breaker (see Figure 1). Applications with high continuous current levels require connections with large conductors of very low impedance. These conditions cause unique fault current and voltage conditions (see Figure 3).

## High Continuous Current Levels

Generator circuit breakers must be able to handle high continuous current levels.

The Cutler-Hammer VCP-WG Circuit Breakers are designed to reliably operate up to 4000 amperes with natural air convection cooling, and up to 5000 amperes with suitable enclosure fan cooling during overload conditions. Continuous current ratings, up to 8000 amperes, can be achieved with natural air convection cooling by coupling two 4000 ampere generator circuit breakers in parallel. Continuous current ratings above 8000 amperes can be achieved by using paralleled circuit breakers with forced air-cooling.

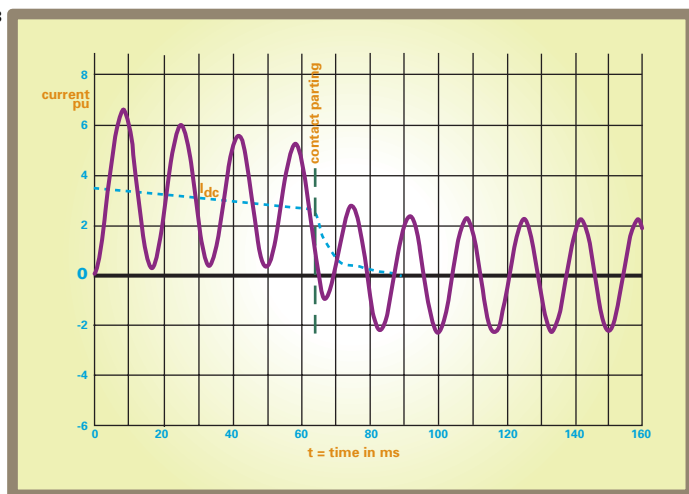

### 1. Generator Circuit Configuration

Generator circuits have a unique configuration. Transformer-fed faults (a) and Generator-fed faults (b) are two of the unique fault current conditions the Cutler-Hammer VCP-WG is designed to handle.

### 2. Test Report Cover Sheets for the Generator Breaker Line

### 3. Delayed Current Curve

Generator-fed faults can experience Delayed Current Zero, where the high inductance to resistance ratio of the system can cause the DC component of the fault current to exceed 100%.

# Power through Extreme Out-of-Phase Voltages, Reliably.

## Safely Switch High-Stress DC Fault Current Content, Robustly.

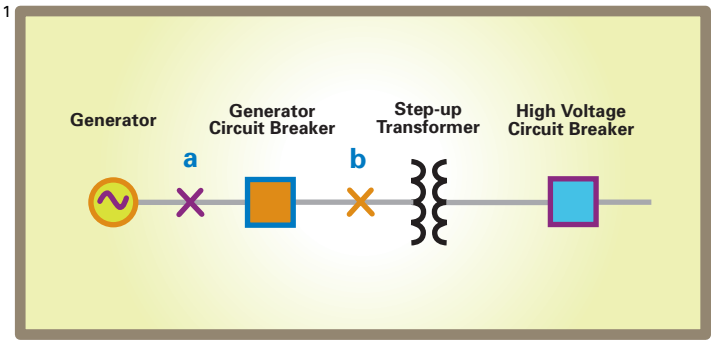

### Unique Fault Current Conditions

Transformer-fed faults (see Figure 1, fault location “a”) can be very high. The full energy of the power system feeds the fault and the low impedance of the fault current path does very little to limit the fault current. The VCP-WG Generator Circuit Breakers are ideal for interrupting such high fault currents because they have demonstrated high interruption ratings up to 75 kA, with high DC fault content up to 75%, that are confirmed by IEEE test.

Generator-fed faults (see Figure 1, fault location “b”) can experience a severe condition shown called “Delayed Current Zero” (see Figure 3 on Page 3). The high X/R (Inductance to Resistance) ratio of the system can cause the DC component of the fault current to exceed 100%. The asymmetrical fault current peak becomes high enough and its decay becomes slow enough that the current zero is delayed for several cycles. The circuit breaker experiences longer arcing time and more electrical, thermal and mechanical stress during the interruption. The IEEE requires verification that the circuit breaker can interrupt under these severe conditions.

### 2 DRAWOUT GENERATOR CIRCUIT BREAKER RATED VALUES

Identification Drawout Generator Circuit Breaker Type ②	Rated Values ①				
	Voltage	Insulation Level		Continuous Current at 60 Hz ③	Short Circuit Current at V (Isc) System Interrupting at V (Isc)
	Max. Voltage V	Withstand Test Power Frequency (1 Min.)	Lightning Impulse (1.2 x 50)		
	kV rms	kV rms	kV Peak	A rms	kA rms Total
50 VCP-WG 50	4.76	19	60	1200 2000 3000	50
50 VCP-WG 63	4.76	19	60	1200 2000 3000	63
50 VCP-WG 75	4.76	19	60	1200 2000 3000 4000	75
150 VCP-WG 50	15	36	95	1200 2000 3000	50
150 VCP-WG 63	15	36	95	1200 2000 3000	63
150 VCP-WG 75	15	36	95	1200 2000 3000 4000	75

Cutler-Hammer VCP-WG Generator Circuit Breakers have demonstrated their ability to interrupt three-phase fault current levels up to 135% DC content with delayed current zero.

#### Unique Voltage Conditions

Generator circuits typically experience very fast rates of rise of recovery voltage (RRRV)

due to their high natural frequency and low impedance and stray capacitance. Cutler-Hammer VCP-WG Generator Circuit Breakers are designed to interrupt fault current levels with very fast RRRV in accordance with IEEE.

Cutler-Hammer VCP-WG Generator Circuit Breakers have a distinct ability to perform

under out-of-phase conditions when the generator and power system voltages are not in sync. The voltages across the open contacts can be as high as twice the rated line-to-ground voltage of the system. IEEE requires demonstration by test that the generator circuit breaker can switch under specified out-of-phase conditions.

#### 1. Generator Circuit Configuration

Generator circuits have a unique configuration. Transformer-fed faults (a) and Generator-fed faults (b) are two of the unique fault current conditions the Cutler-Hammer VCP-WG is designed to handle.

#### 2. Notes

- ① For complete assigned generator circuit breaker ratings, see table on Page 5.
- ② For fixed-mounted circuit breakers, specify type VCP-WRG.
- ③ Higher continuous current ratings possible with forced air enclosure cooling and/or parallel breaker enclosure arrangements.

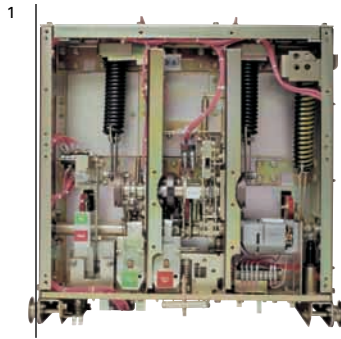

# Interrupt Large Short Circuit Currents with a Small Three-Pole Package.

## Power Protection in a Box Rather than a Room.

### 2 TYPE VCP-WG GENERATOR CIRCUIT BREAKER RATINGS

Generator Circuit Breaker Ratings Assigned C37.013 — 1997	Ratings Assigned Type 150 VCP-WG 50		Ratings Assigned Type 150 VCP-WG 63			Ratings Assigned Type 150 VCP-WG 75		
Maximum Voltage	15 kV		15 kV			15 kV		
Voltage Range Factor (K) (ref.)	1.0		1.0			1.0		
Rated Frequency	60 Hz		60 Hz			60 Hz		
Dielectric Withstand Voltages:								
Lightning Impulse Withstand (1.2 x 50 $\mu$ s)	95 kV		95 kV			95 kV		
Power Frequency Withstand (1 Minute)	36 kV		36 kV			36 kV		
Continuous Current	3000 A (or 4000 A f.c.)		3000 A (or 4000 A f.c.)			4000 A (or 5000 A f.c.)		
Operating Duty Cycle	CO – 30 min – CO		CO – 30 min – CO			CO – 30 min – CO		
Location of Fault	“a”	“b”	“a”	“b”	“b”	“a”	“b”	“b”
Short-Circuit Current	50 kA	25 kA	63 kA	31.5 kA	40 kA	75 kA	40 kA	50 kA
Interrupting Time (3 Cycles)	50 ms	50 ms <sup>1</sup>	50 ms	50 ms <sup>1</sup>	40 ms <sup>1</sup>	83 ms	83 ms <sup>1</sup>	83 ms <sup>1</sup>
Minimum Opening Time	32 ms	32 ms	30 ms	30 ms	30 ms	54 ms	54 ms	54 ms
dc Component	75%	135%	76%	135%	110%	58%	130%	110%
Delayed Current Zeroes <sup>2</sup> (Very Long Arcing Time)	n/a	27 ms	n/a	22 ms	16 ms <sup>3</sup>	n/a	22 ms	22 ms
Asymmetry Factor (S) (ref.)	1.46	2.16	1.47	2.16	1.85	0.63	2.09	1.85
Asymmetrical Interrupting Capability (ref.)	73 kA rms	54 kA rms	92.5 kA rms	67.9 kA rms	74.0 kA rms	47 kA rms	83.7 kA rms	92.5 kA rms
Close and Latch Capability	137 kA Peak		173 kA Peak			206 kA Peak		
Short-time Current	50 kA		63 kA			75 kA		
Duration of Short-time Current	3 s		3 s			1 s		
Transient Recovery Voltage	“a”	“b”	“a”	“b”	“b”	“a”	“b”	“b”
RRRV	3.5 kV/ $\mu$ s	1.6 kV/ $\mu$ s <sup>4</sup>	3.7 kV/ $\mu$ s	1.6 kV/ $\mu$ s	1.6 kV/ $\mu$ s	0.5 kV/ $\mu$ s <sup>2</sup>	0.6 kV/ $\mu$ s <sup>2</sup>	0.7 kV/ $\mu$ s <sup>2</sup>
Peak (E2) <sup>5</sup>	27 kV	28 kV	29 kV	28 kV	28 kV	28 kV	28 kV	28 kV
Time-to-Peak (T2)	8.8 $\mu$ s	19.3 $\mu$ s	8.9 $\mu$ s	19.9 $\mu$ s	19.3 $\mu$ s	65 $\mu$ s	50 $\mu$ s	47 $\mu$ s
Rise Time (t <sub>r</sub> ) (ref.)	7.7 $\mu$ s	17.0 $\mu$ s	7.8 $\mu$ s	17.5 $\mu$ s	17.0 $\mu$ s	57 $\mu$ s	44 $\mu$ s	41 $\mu$ s
Out-of-Phase Switching Duty Voltage	21.2 kV		21.6 kV			21.6 kV		
Breaking Current	25 kA		31.5 kA			40 kA		
dc Component	75%		75%			75%		
Max. Making Current (V-0)	86 kA, Peak		86 kA, Peak			110 kA, Peak		
Making Current at Max. Voltage	45 kA, Peak		45 kA, Peak			60 kA, Peak		
Transient Recovery Voltage								
RRRV	3.4 kV/ $\mu$ s		3.4 kV/ $\mu$ s			3.3 kV/ $\mu$ s		
Peak (E2)	39 kV		45 kV			39 kV		
Time-to-Peak (T2)	15 $\mu$ s		14.9 $\mu$ s			13.0 $\mu$ s		
Rise Time (t <sub>r</sub> ) (ref.)	13 $\mu$ s		13 $\mu$ s			11.4 $\mu$ s		
Mechanical Endurance (No-Load Operations)	5000		5000			10,000		

#### 1. Type VCP-WG Generator Circuit Breaker

Easy access to the mechanism with front cover removed.

#### 2. Notes

<sup>1</sup> Assuming Asymmetry <100%.

<sup>2</sup> This RRRV Capability will require TRV capacitors in most generator circuits, as noted in the last paragraph in Section 7.3.6.1 of C37.013.

“A system with a TRV that exceeds the rated values must be modified in such a way as to lower the TRV. This is achieved by placing a low ohmic resistor in parallel with the main interrupting device of the generator circuit breaker, or by connecting capacitors to its terminals, usually on the transformer side.”

<sup>3</sup> Breaker was able to force current zeroes earlier in 40 kA test circuit.

<sup>4</sup> Tests performed with Direct Testing Circuit, so TRV rate was lower. TRV capacitors are not required for this duty.

<sup>5</sup> TRV peak values may be suppressed when current is highly asymmetric.



# Draw It Out or Fix it In for Maximum End User or OEM Application Versatility.

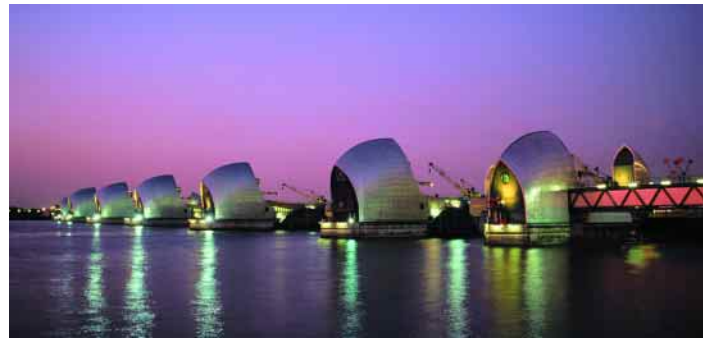

## Versatility in Application

VCP-WG Generator Vacuum Circuit Breakers are available in drawout (VCP-WG) or fixed (VCP-WGR) configurations to provide for superior performance and versatility in application. Many industrial and commercial power systems now include small generators as a local source of power. New applications are arising as a result of the de-regulation of the utility industry, and the construction of smaller packaged power plants. Typical applications include:

- Electric Utilities: Fossil, Hydro and Wind Power
- Packaged Power Plants
- Industrial Companies using Combined Cycle/ Combustion Turbine Plants
- Government and Military
- Commercial Institutions
- Petro-Chem and Process Industries
- Forestry, Pulp and Paper
- Mining, Exploration and Marine

The VCP-WG is the World's Generator Breaker for reliable and robust power generation protection.

Contact your local sales engineer or call 1.800.525.2000 to find out more about the Cutler-Hammer VCP-WG by Eaton.

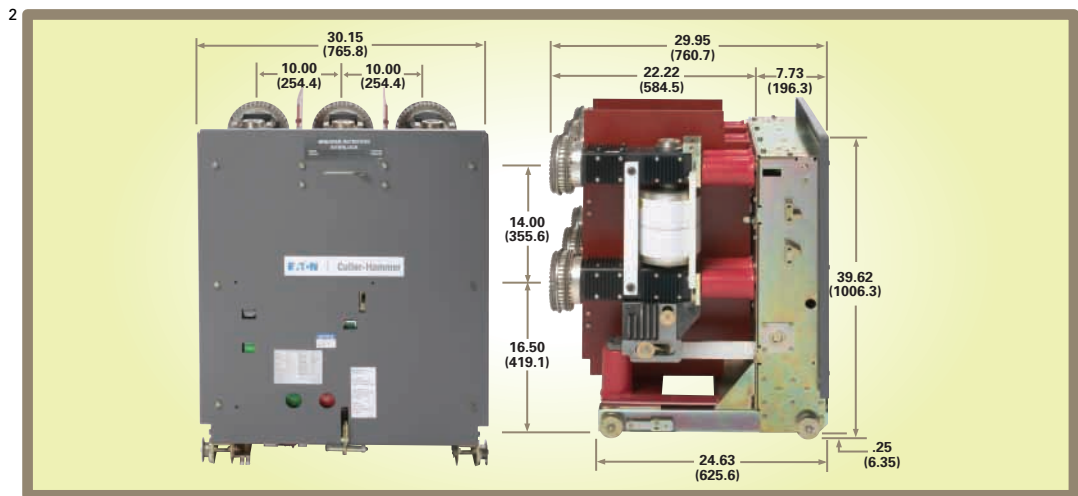
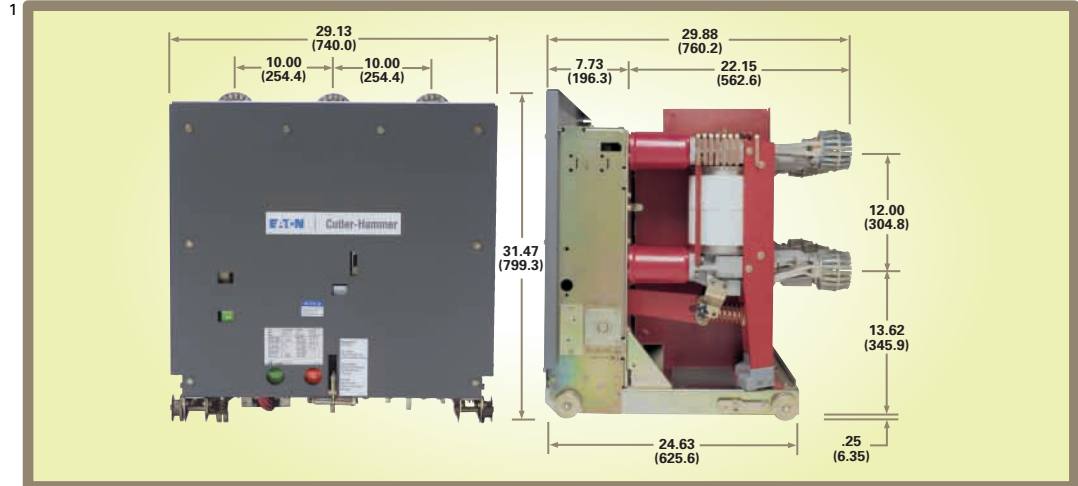

### 1. Dimensions for 63 kA, 3000 A

Approximate weight is 550 lbs. (250 kg).

### 2. Dimensions for 75 kA, 4000 A

Approximate weight is 950 lbs. (431 kg).



**Eaton's electrical business is a global leader in electrical control, power distribution, and industrial automation products and services. Through advanced product development, world-class manufacturing methods, and global engineering services and support, Eaton's electrical business provides customer-driven solutions under brand names such as Cutler-Hammer®, Powerware®, Durant®, Heinemann®, Holec® and MEM®, which globally serve the changing needs of the industrial, utility, light commercial, residential, and OEM markets. For more information, visit [www.EatonElectrical.com](http://www.EatonElectrical.com).**

**Eaton Corporation is a diversified industrial manufacturer with 2004 sales of \$9.8 billion. Eaton is a global leader in electrical systems and components for power quality, distribution and control; fluid power systems and services for industrial, mobile and aircraft equipment; intelligent truck drivetrain systems for safety and fuel economy; and automotive engine air management systems, powertrain solutions and specialty controls for performance, fuel economy and safety. Eaton has 57,000 employees and sells products to customers in more than 125 countries. For more information, visit [www.eaton.com](http://www.eaton.com).**

Eaton Electrical Inc.  
1000 Cherrington Parkway  
Moon Township, PA 15108  
United States  
tel: 1-800-525-2000  
[www.EatonElectrical.com](http://www.EatonElectrical.com)

Cutler-Hammer is a federally registered trademark of Eaton Corporation. The Institute of Electrical and Electronics Engineers Standard C37.013-1997, entitled "IEEE Standard for AC High-Voltage Generator Circuit Breakers rated on a Symmetrical Basis" addresses the special requirements of generator circuit breakers.

**EATON**

**Cutler-Hammer**

© 2005 Eaton Corporation  
All Rights Reserved  
Printed in USA  
Publication No. BR01301001E / Z3683  
October 2005