

EAT•N

Holec

**Magnefix 3.6 - 15 kV
Insulation enclosed switchgear**

Product Focus

- **Compact switchgear
for medium voltage
distribution**



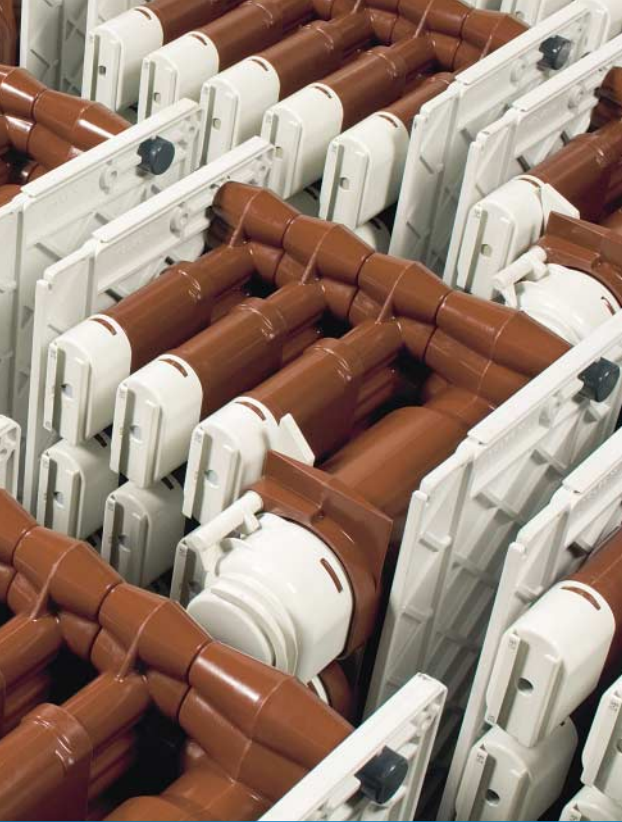

Magnefix

Magnefix is applied in, amongst other locations, decentralised transformer stations, high rise buildings, consumer connections, wind turbine connections and for the electrical supply to signalling and protection equipment along railway tracks.

'The most compact ring main unit'

Creating Solutions

Eaton's Holec brand focuses on creating power-engineering solutions assuring safe and reliable supply of electrical energy. With manufacturing subsidiaries and sales organisations world-wide, Eaton focuses on electrical distribution and power supply in both low and medium voltage ranges.

Eaton's Holec brand

The medium voltage activities of Eaton Electric B.V. are directed towards switchgear installations and components for applications in distribution networks (main and substations, transformer stations) and for industrial power supply. The switchgear systems are air or epoxy resin insulated and are in most cases equipped with circuit-breakers based on Eaton vacuum interrupters. Eaton thus offers an extensive range of switchgear systems and switchgear components, ensuring a safe and reliable distribution of electrical energy.

High level technology

Eaton has more than fifty years experience in manufacturing insulation enclosed switchgear and is recognised throughout the world as being a specialist in the field of epoxy resin based insulation technology. More than 200,000 Magnefix switchboards have been supplied to satisfied customers all over the world.

Magnefix, a timeless design

Magnefix was first introduced onto the market more than 50 years ago. Especially the smart design, safe and robust construction and easy operation have made Magnefix "timeless".

New developments are still being carried out and research into new applications and technologies is continuing unabated. Eaton's engineers are continuously working on improvements in the design and efficiency, and Magnefix users can count on maximum support and the associated service.



Magnefix in walk-in and compact type transformer stations.

The characteristics

- **Extremely compact**

Epoxy resin is not only a high quality insulating material but due to its high mechanical strength, also an excellent construction material. This combination produces a very compact design. The compact construction and full insulation enclosed design of Magnefix equipment enables it to be installed in very small spaces. This results in considerable savings in building costs.

- **Safe and reliable**

Magnefix is a fully insulation enclosed type of switchgear. All live parts are surrounded by insulating material in such a way that touching is impossible.

- **Insulation**

The primary insulation of the Magnefix system consists of epoxy resin with powdered quartz as filling material. This ensures a very low dielectric loss factor (also with

high temperatures), high insulation breakdown factor, very low moisture absorption, high creepage current resistance, high mechanical strength and complete homogeneity. The cable boxes for PILC and XLPE type cables are made of synthetic materials. Magnefix switchgear is provided with double insulation at points accessible to operating personnel. This additional insulation is manufactured and tested independently of the primary insulation.

- **Protected against atmospheric and climatic influences**

The epoxy resin insulation ensures protection against atmospheric and climatic influences. In addition, the material is vibration proof and shock proof and does not age. Magnefix is highly reliable and has a very long life-cycle.

- **Fully tested**

Each Magnefix switchboard is extensively mechanically and electrically tested before it leaves the factory. The test procedures carried out are not only in accordance with the routine tests as specified in the relevant IEC publications, each switchboard is also subjected to additional discharge tests. Consequently, Eaton can guarantee the quality and reliability of each Magnefix switchboard supplied.

- **Earthing**

Before a cable connected to a Magnefix switchboard can be earthed, the switch caps of the unit must be removed. Only then is it possible to fit the earthing caps. The Magnefix unit can only be energized again after the earthing caps have been removed. The earthing caps are designed to make inadvertent earthing of the busbars impossible.



- **Flexible**

Magnefix switchboards have a very modular construction. Any combination can be assembled. Furthermore, various proven methods of cable connections are possible. It is also possible to connect Magnefix to other types of Eaton switchgear.

- **User friendly**

Magnefix switchboards are very easy to handle due to their low weight and small dimensions. The erection time on site is reduced to a minimum thanks to the uncomplicated cable connection. The switching speed is independent of the operating personnel and all switching operations can be carried out in a safe way. Due to the fact that the switch cap is removed when switching off, visible separation is clearly evident to the operating personnel.

- **Cost effective**

One of the most important features of Magnefix is the low price. Not only the initial price is low, the small dimensions mean that it is also possible to reduce the building costs. Furthermore, due to the very long lifecycle and low maintenance costs, the depreciation and exploitation costs are also very low. If desired, a maintenance contract can be arranged with Eaton - Electrical Services & Systems.

- **Environmental friendly materials**

When developing insulation enclosed switchgear, it is important to pay attention to the difference between the dielectric constants of epoxy resin and air, because an optimum transition between both mediums should be obtained. The epoxy resin parts are designed in such a way that no partial discharging can occur on their surfaces. This has been achieved by optimising:



- The thickness of the insulation material
 - The ratio between the epoxy resin and the air clearances
 - The shape of the epoxy resin parts
 - The air circulation over the insulation surfaces.
- In other words, it fits in well with the surroundings. At the end of its lifecycle, the switchboard can be safely disposed of and a large number of parts can be recycled. However, the lifecycle of a Magnefix switchboard can be appreciably extended by carrying out extra maintenance.



- **Kema certified**

Magnefix switchgear has been extensively tested and certified by KEMA. The relevant test reports are available on request.





Magnefix type MD4

Construction

A Magnefix switchboard type MD4 usually comprises a number of cable units to which the main cables are connected (switch-disconnectors), plus one or more protected tee-off units to which the transformer cables are connected (switch-disconnectors combined with fuse-links). A cable unit consists of a fixed portion and three removable switch-caps. The fixed portion is made of epoxy resin, in which the conductors are embedded. The epoxy resin switch caps, in which the moving main and arcing contacts are located, are held in the closed position by high-strength permanent magnets. The latter are not subject to variation, so that the contacts are always MAGNETically FIXed. The various units can be mounted on either a floor frame or a wall frame.

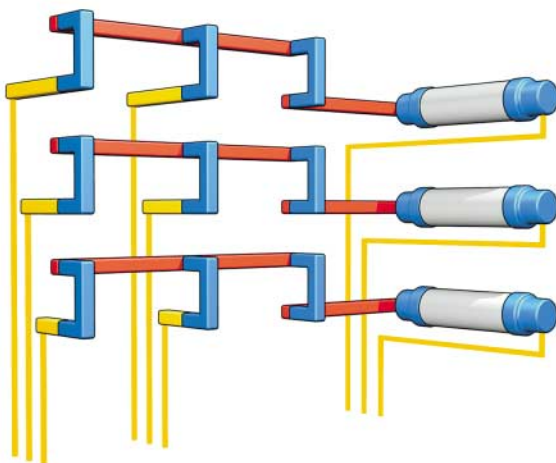

Arrangement of conductors in a ring-main unit

Cable units

The fixed portion of the cable unit contains three terminals to which the cables can be connected. It also contains the corresponding busbar contacts, each fitted with an arcing chamber, the fixed main and arcing contacts and the magnets and pole plates.

The arcing chambers and main and arcing contacts can be replaced when necessary.

The switch caps contain main and arcing contacts, opening springs, springs for ensuring the correct contact pressure and a ferromagnetic plate. These switches have a double break per phase.

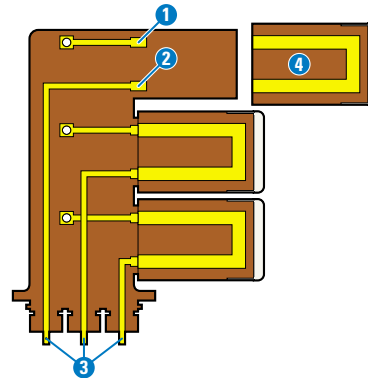

Cross-section of a cable unit

- 1 Busbar contact
- 2 Fixed main contact
- 3 Cable terminals
- 4 Switch cap with main and arcing contacts

Fuse-protected tee-off

The fuse-protected tee-off is used for connection of the transformer and consists of a switch-disconnector and a fuse unit. The switch-disconnector connects the fuse unit to the busbar system. The fuse unit consists of a fixed portion with three terminals for the cables, and three removable fuse holders. The latter are suitable for fuse-links with dimensions in accordance with DIN 43625-12kV. A mechanical interlock between the switch caps of the switch-disconnector and the fuse holders makes it impossible to fit or remove a fuse holder before the corresponding switch cap has been withdrawn. Fuse links can therefore only be fitted or removed when the protected tee-off is switched off. In addition, the contacts on the transformer side of the fuse holder are deeply recessed, so that accidental touching is impossible.

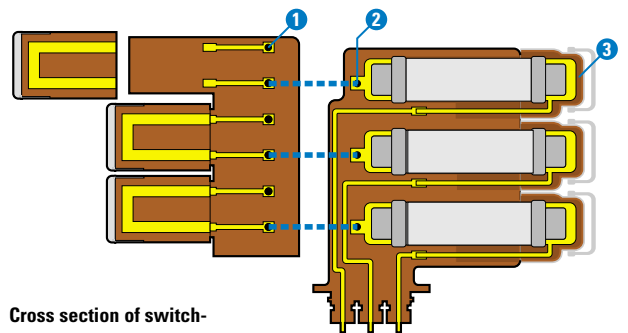

Cross section of switch-disconnector and fuse unit

- 1 Busbar contact
- 2 Fixed contact fuse unit
- 3 Fuse holder

Circuit-breaker protected tee-off

This switching unit (only available in the Magnefix MD4 design) is provided with a three phase vacuum circuit-breaker with an independant operating electronic tripping function. By applying a spring mechanism and vacuum interrupters instead of fuses, the possibility is created for three phase tripping of an overload or short circuit current. The circuit-breaker is connected in series with three single phase switching caps and is suitable for automatic tripping only. Reclosing after tripping is accomplished manually by means of removing the single phase switching caps, closing the circuit-breaker via the spring mechanism and fitting the single phase switch caps again.



Magnefix type MD4 circuit-breaker protected tee-off.

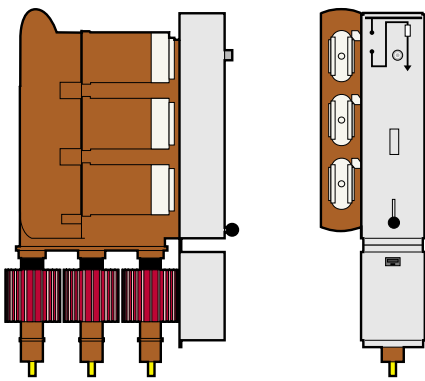

Opening/closing Magnefix type MD4.

Switching

Switching of Magnefix type MD4 is accomplished by fitting or removing the switch caps with an operating handle. The switch cap is placed against the projection on the fixed portion. By pushing the handle forwards, the closing spring in the handle is charged until, at a certain pressure, the resistance of the projection is overcome and the switch cap closes at a speed independent of the operator. The main contacts make contact before the arcing contacts do.

To switch off the Magnefix type MD4, the handle has to be pulled towards the operator, so that the main contacts become disengaged. At this stage, the arcing contacts are still fixed to each other due to the fact that the ferromagnetic plate is still fixed to the magnet. When the opening springs are completely charged, the ferromagnetic plate is pulled off the magnet and the moving arcing contacts are pulled out of the arcing chamber at the required speed, once again independent of the operator.

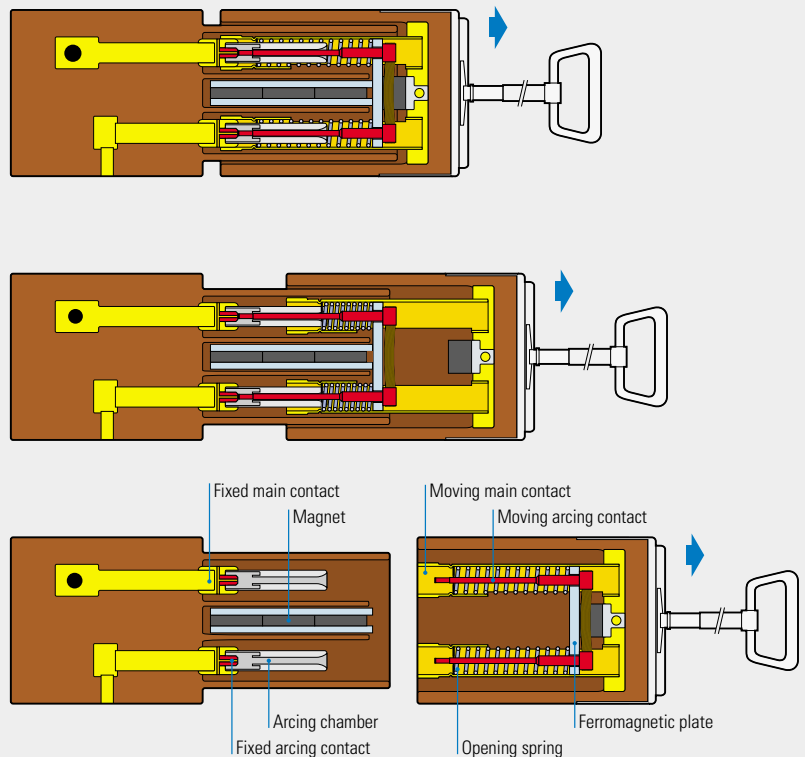

Magnefix type MF

Construction

In principle, the construction of Magnefix type MF is similar to that of Magnefix type MD4. However, type MF can withstand higher normal currents and short-circuit currents.

Magnefix type MF comprises cable units for connection of the main cables, and fuse protected tee-offs. The various units can be mounted on either a floor frame or a wall frame.



Switching

Magnefix type MF is closed by means of an operating handle. Magnefix type MF can be switched off by lifting the grip from the locked position and pulling the switch cap firmly out of the fixed portion. The speed of both operations is independent of the operator.



Opening Magnefix type MF.



Closing Magnefix type MF.

The units

Each switch unit consists of a fixed portion and three removable switch caps. The fixed portion has a protruding epoxy resin insulation collar. After they have been closed, the switch caps are completely located inside this collar. As a result, the caps are extra protected against pollution. The tee-off unit is also provided with an epoxy resin collar. When in service, the fuse holders are also completely covered by this collar. An interlock between the switch-disconnector and the fuse unit ensures that the fuse can only be changed after the switch cap has been removed.

Magnefix arrangements

Assembly

It is possible to assemble switchboards with a wide variety of combinations for various applications. Tie rods ensure that the units and the insulated side plates are clamped together at the right tension. Silver plated tubular conductors- the busbar system- provide the

electrical connections between the units and interconnect the busbar contacts. Each busbar connection is completely insulated, and the entire busbar system is surrounded by epoxy resin insulation.

The basic units for assembly of Magnefix switchgear

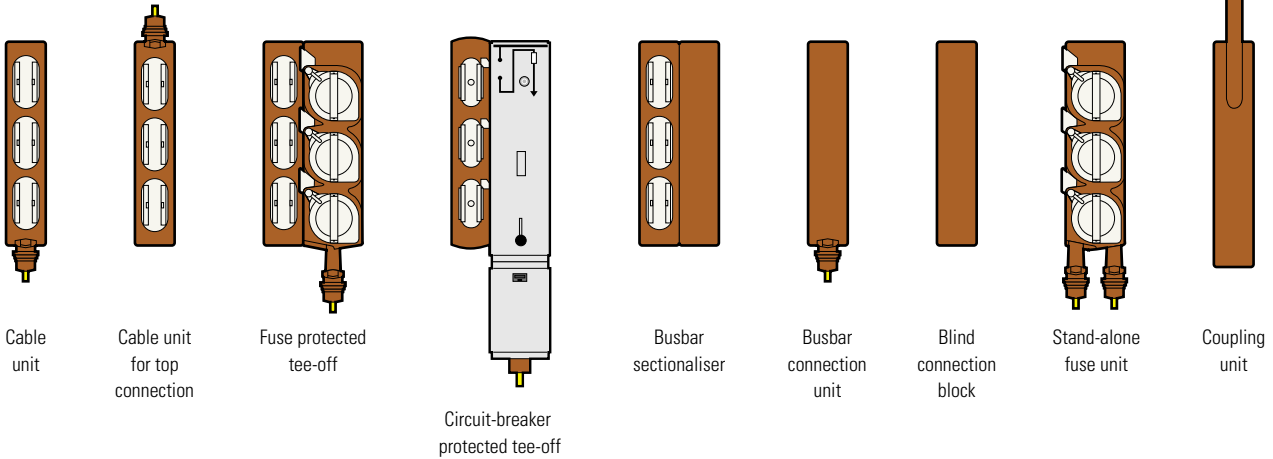

Ring main unit

This is the most common arrangement and consists of two or more cable units and fuse protected tee-offs.

Application
Compact transformer stations and switching points in medium voltage distribution networks.

Ring main unit with top connection

For connecting cables to the top side of a switchboard, a switch-disconnector as described under ring main unit, but with top terminals is available.

Application:
Ideally suitable for Magnefix switchboards erected on various levels of apartment buildings, office blocks etc.

Terminal station

This arrangement comprises a fuse protected tee-off.

Application
Transformer stations at the end of feeder cables. For example for wind turbine connections.

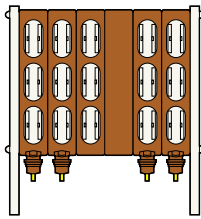

4-way switchboard with busbar sectionaliser unit.

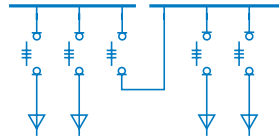

Busbar sectionaliser unit

With a busbar sectionaliser unit, it is possible to have two sections energized independently of each other.

Application:

To isolate consumer owned supply units from the grid connection which is owned by the electricity company.

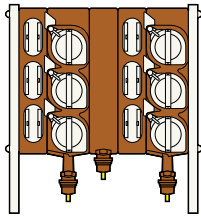

Magnefix switchboard with busbar connection unit.

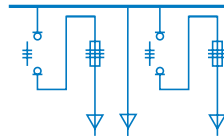

Busbar connection unit

If a cable requires direct connection to the busbar system of a Magnefix switchboard, a busbar connection unit is available.

Application:

Can be used as a junction point for a cable if switching is not required.

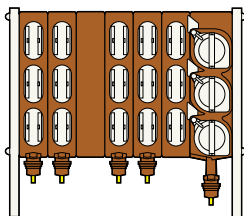

Magnefix switchboard with blind connection block.

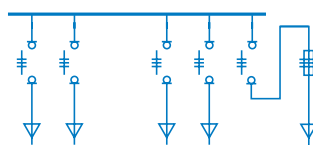

Blind connection block (MD4 only)

A blind connection block can be applied when more space is required between the units or when the switchboard is divided by a wall.

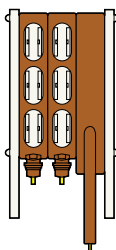

Switchboard with coupling unit.

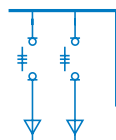

Coupling unit

Coupling units can be applied to connect Magnefix switchboards to other types of Eaton switchgear.



Fuse unit with 6 cable terminals.



Fuse unit

If only a single fuse unit is required, a unit with 6 cable terminals is available.

Application

When a fuse unit is placed separate from its switch-disconnector.

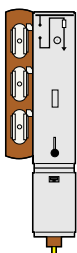

Circuit-breaker protected tee-off (MD4 only)

Switching unit provided with a three phase vacuum circuit-breaker with an independent operating electronic tripping function. By applying a spring mechanism and vacuum interrupters instead of fuses, the possibility is created for three phase tripping of an overload or short-circuit current. Switching on is accomplished single phase manually.

Application

- Protected connection of extra ring cables in existing distribution networks.
- Protected connection of distribution transformers.

Short-circuit indicators

Short-circuit indicators are instruments which are operated by the magnetic field of a conductor through which current is flowing and indicate that this has occurred. By using short-circuit indicators, the time taken to locate faults in medium voltage networks is greatly reduced. When the current at which the indicator is set is exceeded, an orange flag appears in the window.

Two versions of this indicator are available:

Magnetic short-circuit indicator

This indicator is operated by the magnetic field caused by an overcurrent and can be reset by moving a reset magnet in front of the indicator.



MD4 switch cap with hand reset short-circuit indicator.



MF switch cap with hand reset short-circuit indicator.

Automatic reset electronic short-circuit indicator

This indicator is also operated by the magnetic field caused by an overcurrent. It has no battery but it uses the energy of the electrical field around the Magnefix switch cap. It will be automatically reset after a fault has been cleared and after the system voltage has returned. The indicator is hermetically sealed thus making it insensitive to dust and moisture.



MD4 switch cap with automatic reset electronic short-circuit indicator.



MF switch cap with automatic reset electronic short-circuit indicator.



Automatic reset electronic short-circuit indicator.



Cable connections

Cable box for paper-insulated lead-covered cables (PILC)

Armoured paper-insulated lead-covered cables are connected to cable units and fuse units by means of grease filled plastic cable boxes. These cable boxes can be supplied in various sizes up to 240 mm². They have staggered inlets, metal soldering glands or plastic glands.

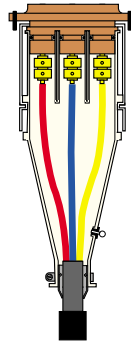

Cable box for solid insulated XLPE cables

For connecting three phase or single phase solid insulated cables up to 240 mm², a so-called "dry" type cable box can be supplied. No cable grease or compound is therefore needed. When required (depending on the length of the cable connection) extra shielding can be mounted.

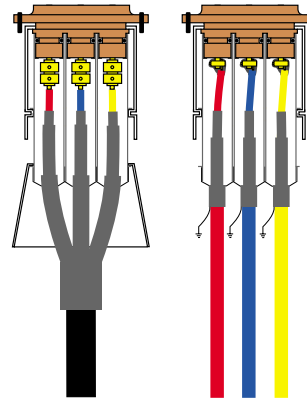

Transformer connection for Magnefix type MF.

Single-core transformer cables

Completely prefabricated polythene insulated cables 1 x 16 mm² Cu can be ordered to any required length.

Magnefix type MF protected tee-off units are provided as standard with three openings for direct insertion of these single-core transformer cables.



Technical data

Magnefix type		MD4			MF			
Rated values								
Voltage	kV	3.6	7.2	12	3.6	7.2	12	15
Impulse withstand voltage	kV	40/46	60/70	75/85	40/46	60/70	75/85	95/110
Power frequency withstand voltage	kV	10/12	20/23	28/32	10/12	20/23	28/32	38/45
Frequency	Hz	50-60	50-60	50-60	50-60	50-60	50-60	50-60
Busbar system								
Normal current	A	400	400	400	630	630	630	630
Short-time withstand current 1 s.	kA	14.4	14.4	14.4	20	20	20	20
Peak withstand current	kA	31	31	31	50	50	50	50
Switch-disconnector								
Normal current	A	400	400	400	450	450	450	450
Mainly active load breaking current	A	400	400	400	450	450	450	450
Short-circuit making current peak value	kA	31	31	31	50	50	50	50
Short-time withstand current 1 s.	kA	14.4	14.4	14.4	20	20	20	20
Earth fault breaking current	A	240	240	240	240	240	240	240
Cable charging breaking current	A	25	25	25	25	25	25	25
Circuit-breaker								
Normal current	A	400	400	400	-	-	-	-
Short-time withstand current 1 s.	kA	14.4	14.4	14.4	-	-	-	-
Short-circuit breaking current peak value	kA	14.4	14.4	14.4	-	-	-	-
DC component	%	20	20	20	-	-	-	-
Making current	A	-	-	-	-	-	-	-
Fuse-links								
Normal current	A	57.7	57.7	57.7	57.7	57.7	57.7	57.7
Fuse-links according to DIN 43625	kV	12	12	12	12	12	12	12



Standards

Magnefix MD4 and MF switchgear comply with the following IEC publications

IEC60694 / IEC62271-1	Common specifications for high-voltage switchgear and controlgear standards
IEC60056 / IEC62271-100	High-voltage alternating-current circuit-breakers
IEC60129 / IEC62271-102	Alternating current disconnectors and earthing switches
IEC60265 / IEC62271-103	High-voltage switches
IEC60466 / IEC62271-201	A.C. insulation-enclosed switchgear and controlgear for rated voltages above 1 kV and up to and including 52 kV
IEC60529	Degrees of protection provided by enclosures
IEC60185 / IEC60044-1	Instrument transformers - Part 1: Current transformers

Classification according to IEC 62271-201

Protection grade against electric shock	PA/PB1
Loss Of Service Continuity	LSC 1
Partition Class	PI
IAC	Not applicable
Degree of protection	IP 2X

Above summary gives for some subjects the old and the new standards.

Magnefix switchgear is tested according to the IEC standard as applicable at the time of the type tests.

Dimensions (mm)

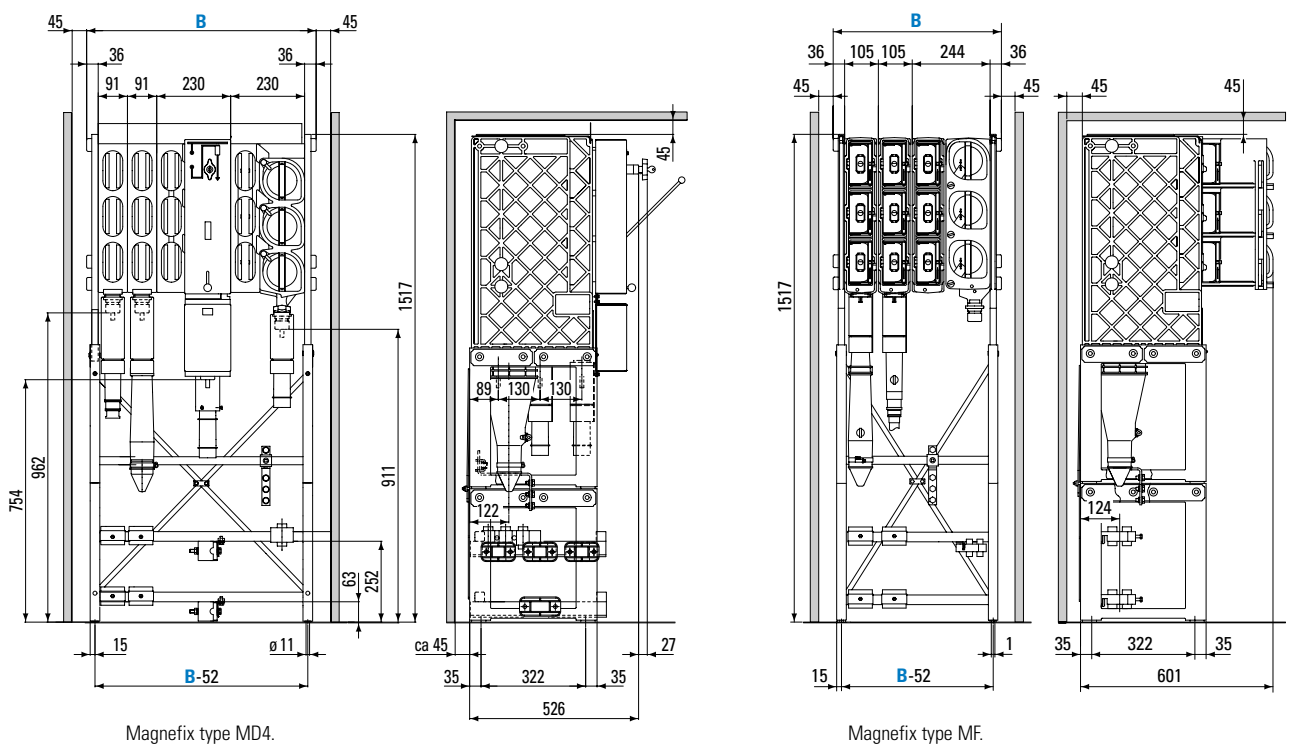

Dimensions (mm)	Magnefix type MD4	Magnefix type MF
Unit widths		
Cable unit	91	105
Busbar connection unit	91	105
Cable unit for top connection	91	210
Blind connection block	91	-
Busbar sectionaliser	182	210
Fuse protected tee-off	230	244
Circuit-breaker protected tee-off	230	-
Total width calculations	B = C x 91 + T x 230 + 72	B = C x 105 + T x 244 + 72

(C = number of cable units, T = number of protected tee-offs)

Accessories for Magnefix type MD 4



Device for testing and measuring cables.



Earthing device (standard).



Earthing device with ball-shaped contact suitable for phase-sequence measuring.



Earthing device for transformer cable with ball-shaped contact.



Closing and opening handle.



Switch cap with hand reset short-circuit indicator.



Switch cap with automatic reset electronic short-circuit indicator.



Protection cover for protecting the contacts on the inside of the fixed portions when the switch caps or fuse holders are removed.



Tool case for maintenance.



Quick-acting earthing device for three-phase earthing.



Three-phase switching device.



Single phase voltage tester for checking whether the cables or main busbar system are energized.

Accessories for Magnefix type MF



Earthing device (standard).



Quick-acting earthing device for three-phase earthing.



Earthing device with ball-shaped contact.



Earthing device for transformer cable with ball-shaped contact.



Closing handle.



Switch cap with hand reset short-circuit indicator.



Switch cap with automatic reset electronic short-circuit indicator.

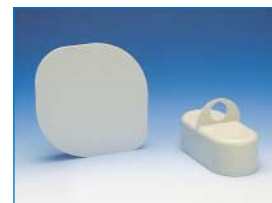

Protection covers for protecting the contacts on the inside of the fixed portions when the switch caps or fuse holders are removed.



Padlockable interlocking plate to prevent a unit from being operated when not desired.



Device for testing and measuring cables.



Single phase voltage tester for checking whether the cables or main busbar system are energized.

Eaton - advice and service

Depending on the condition of the switchgear and the site conditions, maintenance may be required. Eaton can carry out this work or train local service engineers. An extensive study has been carried out on more than one hundred distribution switchboards, as a result of which professional maintenance and test equipment has been developed. This equipment is also available for your service department. Together with the manufacturing of high quality electrical switchgear Eaton offers service and advice. Should an emergency occur, Eaton can supply new Magnefix switchgear in Europe within 24 hours.

In case of emergency:

Eaton - Electrical Services & Systems, available 24/7.
Tel.: +31 74 246 6888

Quality

Eaton has been meeting the ISO 9001 quality assurance requirements since 1989. This quality assurance system calls for a periodic evaluation of the organizational structure, the assignment of responsibilities and the associated procedures. It also guarantees corrective action and activities when required. This keeps the quality assurance system up to standard and enables adjustments to be made and further development to take place where necessary.



Eaton Corporation is a diversified industrial manufacturer ranked among the largest Fortune 500 companies. The electrical group is Eaton's largest division and is a global leader in electrical control, power distribution, power quality, automation, and monitoring products and services. Eaton's electrical products include brands such as Cutler-Hammer®, MGE Office Protection Systems, Powerware®, Holec®, and MEM®. Eaton provides PowerChain Management® solutions to serve the needs of the industrial, institutional, IT, data center, mission critical, utility, residential and OEM markets worldwide.

PowerChain Management solutions help enterprises achieve sustainable and competitive advantages through proactive management of the power system as a strategic, integrated asset throughout its life cycle. With Eaton's distribution, generation and power quality equipment; full-scale engineering services; and information management systems, the power system is positioned to deliver powerful results: greater reliability, operating cost efficiencies, effective use of capital, enhanced safety, and risk mitigation.

Eaton medium voltage products in the energy chain

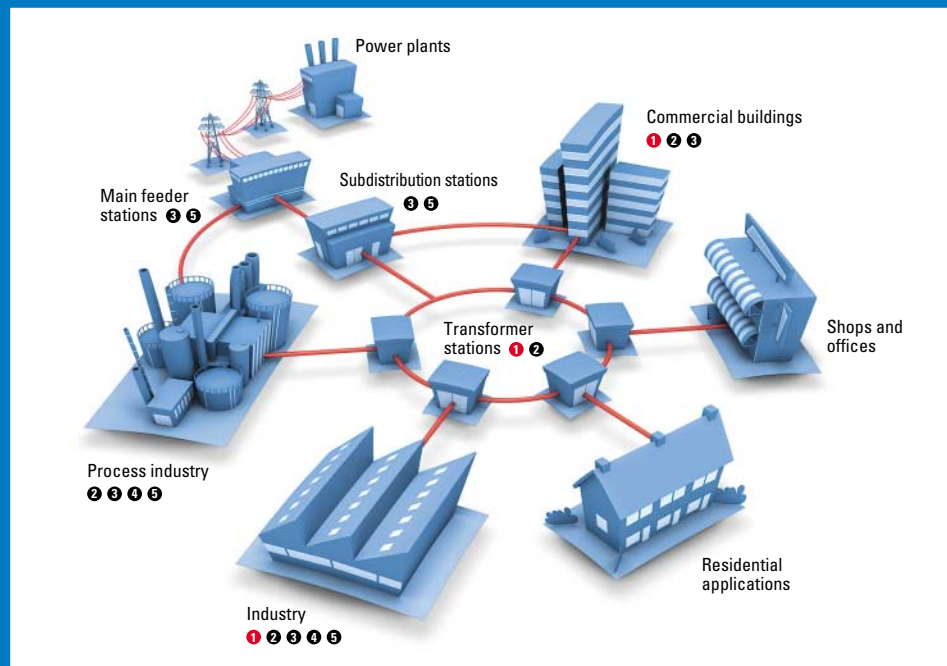

Eaton Electric B.V.
P.O. Box 23
7550 AA Hengelo
The Netherlands
Tel. : +31 74 246 40 10
Fax : +31 74 246 40 25
holec-info@eaton.com



1 Magnefix 2 Xiria 3 Innovac SVS 4 Unitole 5 Innovac MMS



www.eatonelectrical.com

© 2008 Eaton Electric B.V.
All rights reserved.

Printed in The Netherlands.
Form no. 994 069 C/1/SG
March 2008

Due to continuous research and development policy Eaton reserves the right to make changes in design and specifications of the products without prior written notice.