

# EAT•N

# Holec

## Innovac SVS/08 - SVS/12 3.6 - 24 kV modular switchgear

Product Focus

- Epoxy resin insulated switchgear in sheet steel enclosure with vacuum interrupters
- Total reliability in switching, metering and distributing electrical energy with safe components in functional panel versions





### Reliable and safe in operation

Epoxy resin is used in the SVS system as high-quality primary insulation material around live parts. Phases are completely separated by epoxy resin therefore preventing internal arcs. In addition, all primary components are interconnected via rubber sleeves. The same level of insulation is maintained throughout the entire switchgear. Practical research work on installed switchgear reveal that the epoxy resin components in the SVS switchgear show no signs of ageing.

## The SVS system

A fully-enclosed epoxy resin insulated system with integral vacuum interrupters.

SVS is a compact, modular system developed for medium voltage applications up to 24 kV. With flexibility in mind, the panels are assembled from modular components including circuit-breakers, load-break switches, fuse holders, metering panels, busbars and cable terminals. The system is highly suitable for switching and distribution equipment used in electricity distribution networks, as well as in a variety of industrial applications.

Eaton Holec is recognised throughout the world as the leading specialist in epoxy resin-based insulation technology. Vacuum interrupters form the heart of the Eaton Holec switchgear range. These high-quality interrupters have been developed and manufactured by Eaton Holec.



## System design

Eaton Holec's modular SVS system is an example of tried and tested high-quality switchgear technology incorporating vacuum interrupters and epoxy resin insulation.



SVS/08 circuit-breaker panel.

## Modules SVS/08 and SVS/12

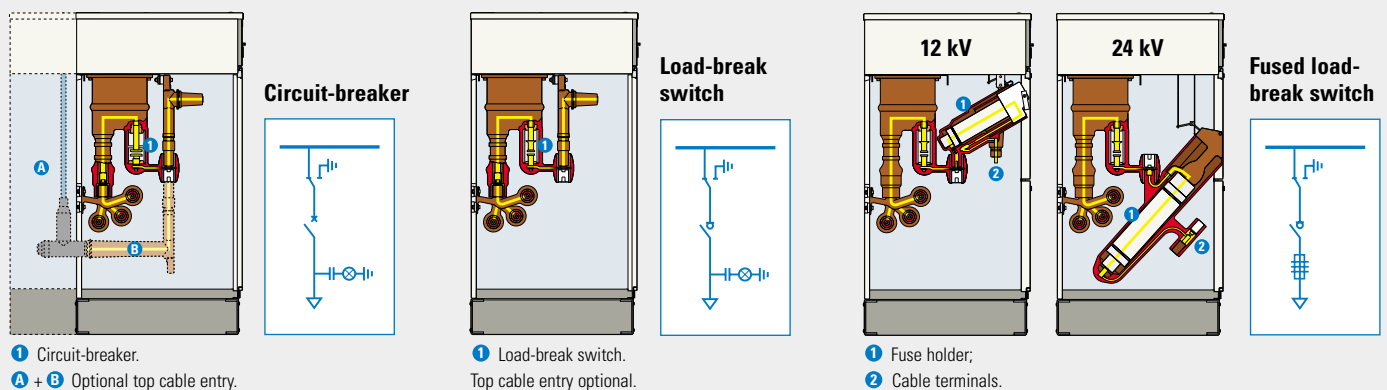



### Safe in use

The earthed metal enclosure of the SVS system provides personal safety during normal operation (protection level IP2XD in conformity with IEC publication 60529). The live primary

parts and primary component connections are fully insulated, removing risk of contact with live parts during maintenance, revision and assembly work. The insulation is resistant to voltage surges and mains frequency restraining voltage occurring with the rated voltage.



### Flexible

The SVS system is modular in construction. This means that any panel combination and sequence is possible. In addition, the number of panels capable of being used in an installation is unlimited as several sections can easily be connected. Existing SVS switchgear can also be easily extended by one or more panels. As the panels can be quickly assembled and connected, flexible commissioning of the switchgear is possible. The panels in the SVS system are compact (min. 420 mm wide), resulting in considerable savings in costs and installation space.

### The changeover switch

All panels with a switching function are equipped with a changeover switch consisting of interconnected contact pins moving in a vertical plane. Since it is mechanically interlocked, the change over switch can only be operated when the load-break switch or circuit-breaker is in the open position.

The change over switch has two positions:

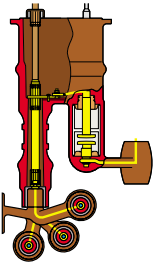

#### Operating position

In this position, the changeover switch is connected to the busbar system so the connection between busbar and outgoing cable can be realised by closing the circuit-breaker or load-break switch.

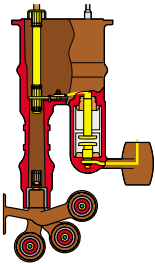

#### Earthed position

In this position the changeover switch is connected to the main earthing conductor. In the earthed position the changeover switch also forms a safe

earthed barrier from the cable connection point to the busbar system.

### The busbar system

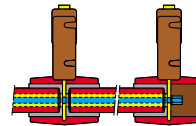

The electrical connection between two panels is provided by three single-phase busbar units, which consist of tubular conductors fully embedded in epoxy resin. These conductors contain

tie rods that clamp the busbar pieces on the various panels together. Due to the elasticity of the tie rods the pressure required remains constant under all load conditions. Rubber sleeves at the connection points provide reliable electrical sealing. It is easy to extend existing installations and to add on further sections.

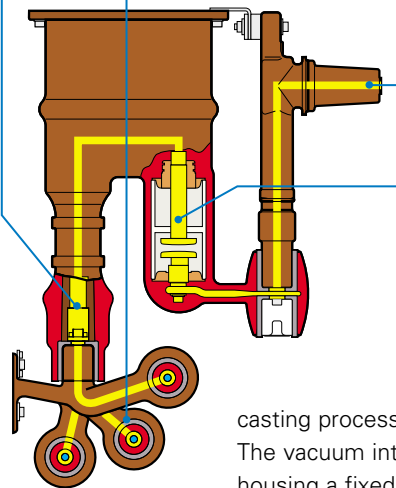

#### Cable connection cone

#### The vacuum interrupter

Vacuum interrupters form the heart of the Eaton Holec switchgear range. To achieve a high level of protection against environmental influences the vacuum interrupters are completely casted in epoxy resin. The direct

casting process is a key competence of Eaton Holec. The vacuum interrupters consist of a ceramic cylinder, housing a fixed and a movable contact. Movement of the contact under vacuum conditions is facilitated by a bellows. A shield surrounding the contacts prevents the insulators from becoming contaminated by metal vapour produced during current interruption. This shield also ensures good potential distribution over the insulator.

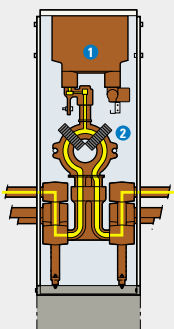

#### Metering panels

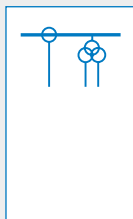

#### Voltage transformers at cable side

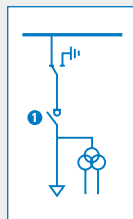

#### Busbar voltage measuring panel

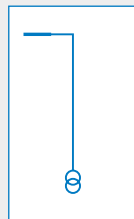

#### Busbar sectionalisers

Load-break switch or circuit-breaker

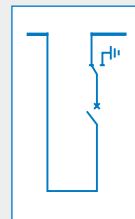
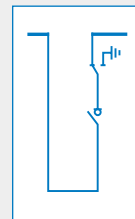

#### Direct busbar connections

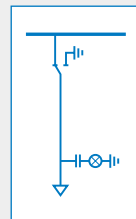
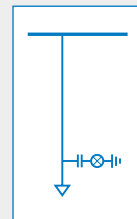

#### Stand alone panel with CB or LBS

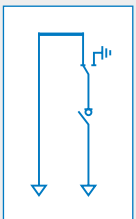

1 Voltage transformers;  
2 Current transformers.

1 For CB and LBS.

Applicable for UK.



### User friendly

The SVS system features uniform and straightforward operation. Each panel has an easy-to-understand and clearly set out mimic diagram, showing every switching action. The cable terminal area is very easy to access. Cables are connected at the front of the panels at a height of 80 - 90 cm. There is ample space for finishing off and securing the cables. All installations are easy to transport using a lifting crane, a fork-lift truck and steel rollers.



### Environmental friendly

Eaton Holec selects its materials with care. It is essential they are safe for people and the environment - not just during use, but at the end of their service life, too. For this reason the SVS system does not contain SF<sub>6</sub> insulation gas and all materials used are environmentally friendly, according to the present state of knowledge.

### Diffuse discharge

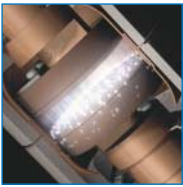

A typical feature of interrupting currents up till the rated short circuit current in the Eaton Holec vacuum circuit-breaker is that a large number of parallel arcs are created between the contacts. This 'diffuse discharge' is characterised by very low arc voltage and short arc

times, resulting in very low arc energy. Contact wear in a vacuum interrupter is therefore virtually negligible. The vacuum interrupter in the load-break switch can switch nominal currents of max. 630 A. The vacuum interrupter in the circuit-breaker can switch short-circuit currents up to a maximum of 20 kA for SVS/08 and 25 kA for SVS/12.

### Vacuum interrupter

- 1 Bellows
- 2 Bellows shield
- 3 Ceramic insulators
- 4 Movable contact
- 5 Magnetic laminations

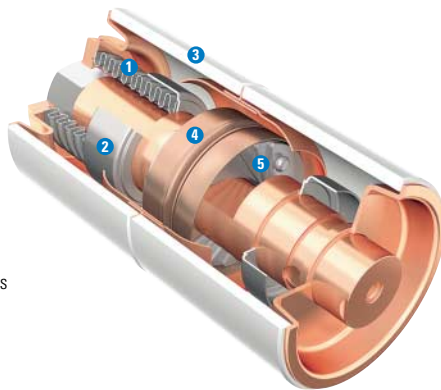

## Application

The SVS system of Eaton Holec is ideally suited for use in distribution networks and as industrial and building switchgear. The system provides reliable switching, protection, metering and distribution of electrical energy. The SVS system is based on vacuum technology combined with solid insulation. This makes the SVS system especially suitable for application in infrastructural projects (i.e. tunnels and subways) and industrial or commercial environments (i.e. processing industry, food industry and hospitals) where a clean and safe environment is necessary. The SVS system is used in:

- **Utility:** (Main) distribution stations, compact secondary substations, wind turbines
- **Infrastructure:** Vacuum switching is especially suitable for tunnels, subways and other infrastructural applications
- **Industries:** Connection to ring cable or LVS system
- **Commercial:** Hospitals, stadiums, shopping centres, hotels, etc.

## Operating panels



SVS/08



SVS/12



## Modules SVS/12

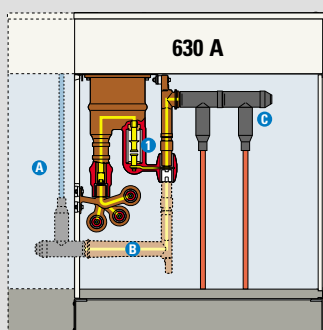

Load-break switch

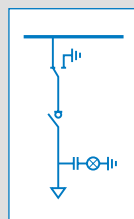

- 1 Load-break switch. A + B Optional top cable entry.
- C Optional second cable connection.

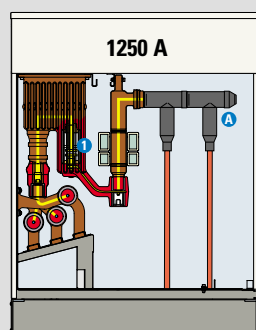

Circuit-breaker

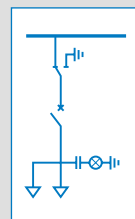

- 1 Circuit-breaker.
- A Optional second cable connection.





Eaton's electrical business is a global leader in electrical control, power distribution, uninterruptible power supply and industrial automation products and services. Eaton's global electrical brands, including Cutler-Hammer®, Powerware®, Holec® and MEM®, provide customer-driven PowerChain Management™ solutions to serve the power system needs of the industrial, institutional, government, utility, commercial, residential, IT, mission critical and OEM markets worldwide.

Eaton Corporation is a diversified industrial manufacturer with 2006 sales of \$12.4 billion. Eaton is a global leader in electrical systems and components for power quality, distribution and control; fluid power systems and services for industrial, mobile and aircraft equipment; intelligent truck drivetrain systems for safety and fuel economy; and automotive engine air management systems, powertrain solutions and specialty controls for performance, fuel economy and safety. Eaton has 62,000 employees and sells products to customers in more than 125 countries.

For more information, visit [www.eaton.com](http://www.eaton.com).

### Eaton Holec medium voltage products in the energy chain

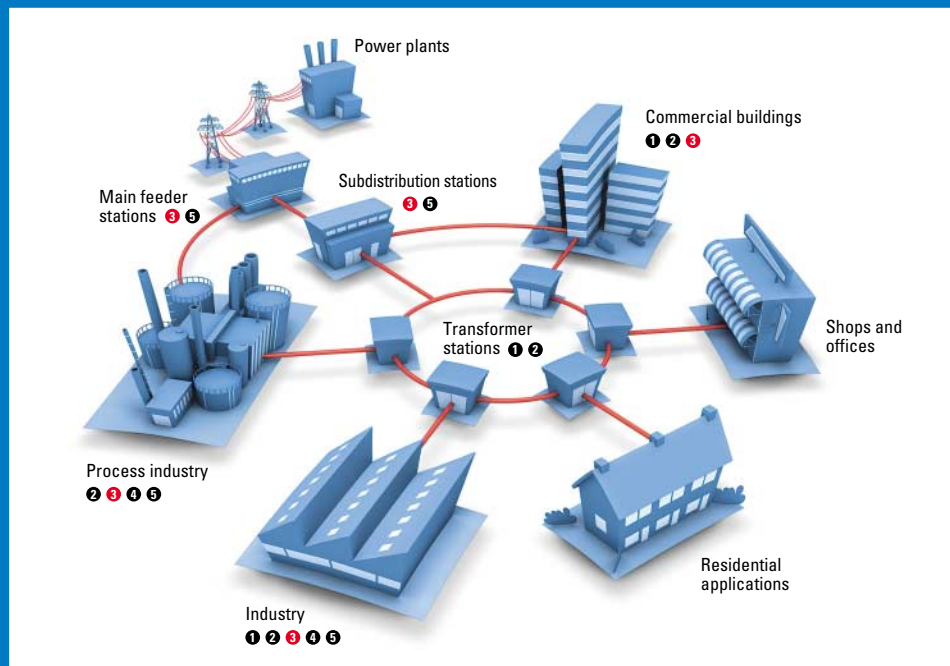

Eaton Electric B.V.  
 P.O. Box 23  
 7550 AA Hengelo  
 The Netherlands  
 Tel. : +31 74 246 40 10  
 Fax : +31 74 246 40 25  
[holec-info@eaton.com](mailto:holec-info@eaton.com)



① Magnefix



② Xiria



③ SVS



④ Unitle



⑤ MMS



[www.eatonelectrical.com](http://www.eatonelectrical.com)

© 2007 Eaton Electric B.V.  
 All rights reserved.

Printed in The Netherlands.  
 Form no. 994 050 001/1/SG  
 October 2007

Due to continuous research and development policy Eaton reserves the right to make changes in design and specifications of the products without prior written notice.